

Product Ref: 6101

The Sanicubic® 1 is a robust macerator pump that has been designed for the discharge of waste from up to two WCs plus multiple grey water producing appliances in busy business environments and larger domestic situations.



Note: Isolation valves must be fitted to the inlet pipework and discharge pipework to isolate the unit in case of the need for service

Why choose this product?

- Ideal for busy business environments and larger domestic situations
- Tough, reliable macerator pump
- New design with easily removable motor for servicing and maintenance
- Water level indicator unit can be easily removed for maintenance
- External hard wired audio visual alarm
- Features integrated non-return valves
- Centre heights of inlets 140mm
- Working temperature of 35°C. Will handle up to 70°C for short periods. (See Sanicom 1 and 2 for higher temperatures and longer periods)
- IP67 rated
- Cannot be connected to a Building Management System

Vertical/horizontal performance

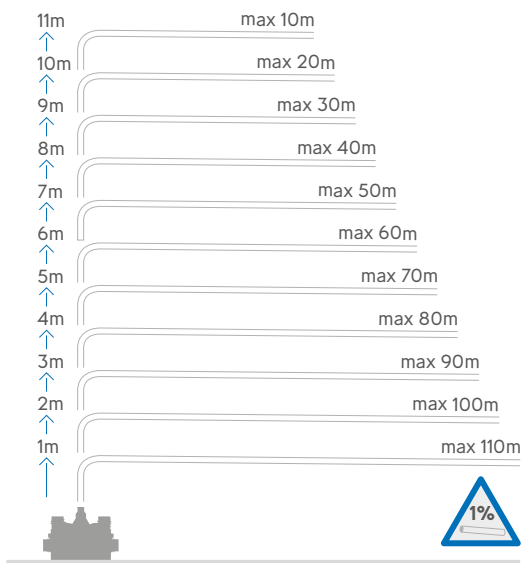

The Sanicubic tank is fitted with 2 dip tubes; one tube controls motor operation and the other controls the alarm system:

- Long pickup tube (normal operation): as soon as the waste water level in the tank reaches the triggering point in the long tube, the pumping system starts up.
- Short pickup tube (inflow overload operation): if the waste water level in the tank reaches the upper point, a contact is closed and the auxiliary pumping system is triggered. The contact also sets off an audible and visual alarm.

IP Ratings

IP or "Ingress Protection" ratings specify the environmental protection that the product casing provides and are defined by international standards. They are used to explain levels of sealing effectiveness of electrical enclosures against intrusion from foreign bodies e.g. dust, dirt and moisture.

Sanicubic 1 has rating IP67 which gives protection against temporary immersion in water.



External hard-wired audio visual alarm (5m cable).

Discharge Pipework
50mm

Motor Power
1500 Watts

Flow Rate
13m³/h

Voltages
220-240 V/50 Hz

Tank Volume
32L

Working Waste Water Temp
35°C/Max 70°C (intermittent)

Product Weight
20kg

Inlet Pipework
40 / 50 / 100 / 110mm

IP Rating
IP67

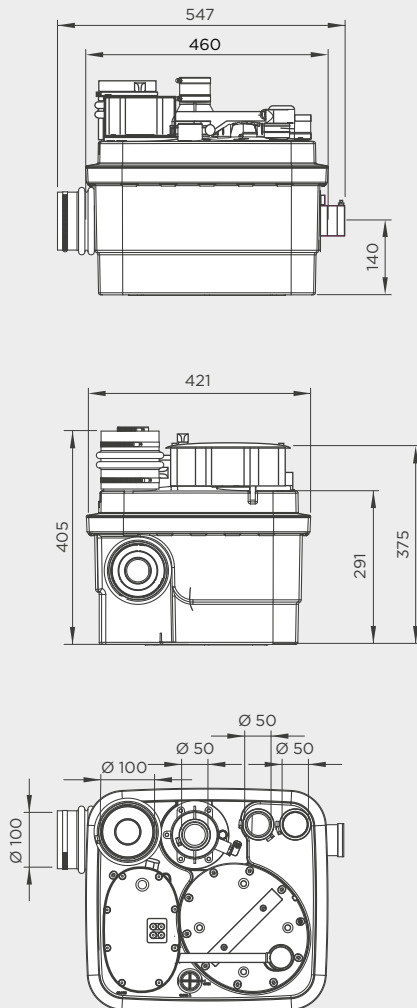

Discharge height (m)

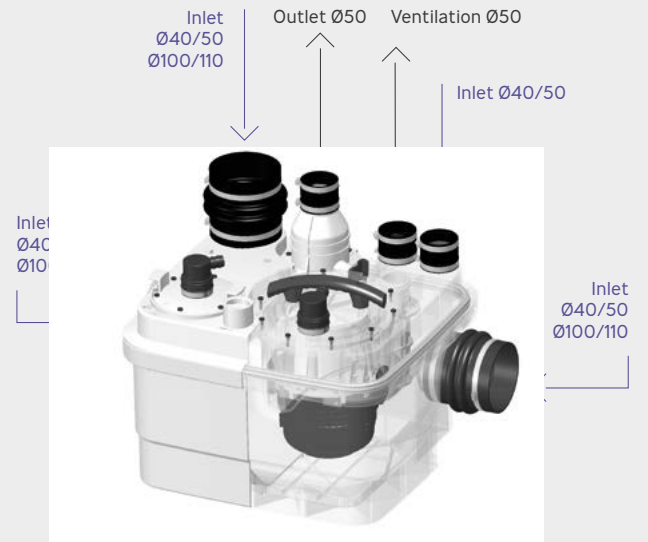
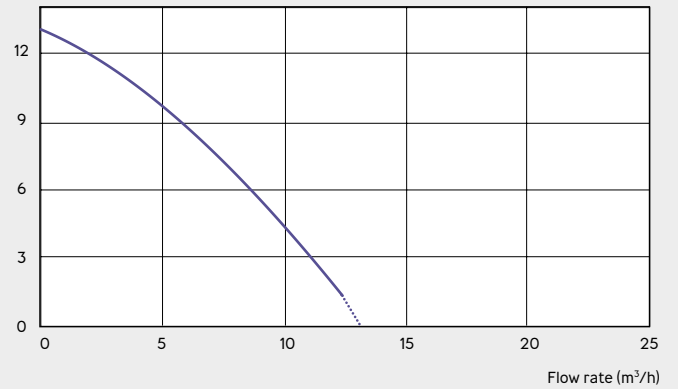

Remote hard-wired audio visual alarm

